

# Counter-Balancing System of Vertical Moving Components Using Rotary Piston

Ing. Štěpán Fiala

Supervisor: Doc. Ing. Antonín Bubák, Ph.D.

## Abstract

The paper deals with the measurement and evaluation of the experiment of balancing vertically moving components of machine motion axes. The drive of the vertical axis is realized via a toothed rack and a pinion. For the purpose of the counterbalance mechanism was used axial piston hydromotor. Connecting to a source of constant pressure was achieved torque on the pinion which compensates gravitational effects of movable machine groups. To the same pinion was parallelly attached a servodrives with an gearbox, which ensured the function of accurate positioning and was a power sources for dynamic movements. Synergy of electric actuator and hydraulic mechanism was explored, as well as their influence on the final positioning accuracy.

## Keywords

Balancing, Machine Tools, Rotary Piston Hydromotor, Servodrives.

## 1. Introduction

Almost every machine that is built on the Earth's surface is exposed to the effect of self-weight of gravity. This force effect is critical for vertical linear axes. To eliminate these force effects, balancing is applied to machines. Balancing means minimizing the effects of self-weight of gravity (steady state). The forces necessary to drive this balanced axis are calculated from the well-known Newton's second Law. This axis balancing reduces demands on installed power of motion axes. The force from the cutting process is added to this strength when machining. [1]

### 1.1 Purpose of balancing

Machine manufacturers now generally aim at saving energy. For instance, using frequency converter with fluid systems with asynchronous motors machine leads to an improvement in energetic efficiency at least 10%. The potential to save energy lies in servomotors. Looking into the model of cascade regulatory scheme with brushless motor and single mass system makes obvious why balancing is important. Gravitational forces do not act in the direction of movement as far as the machine's horizontally moving axis is involved.

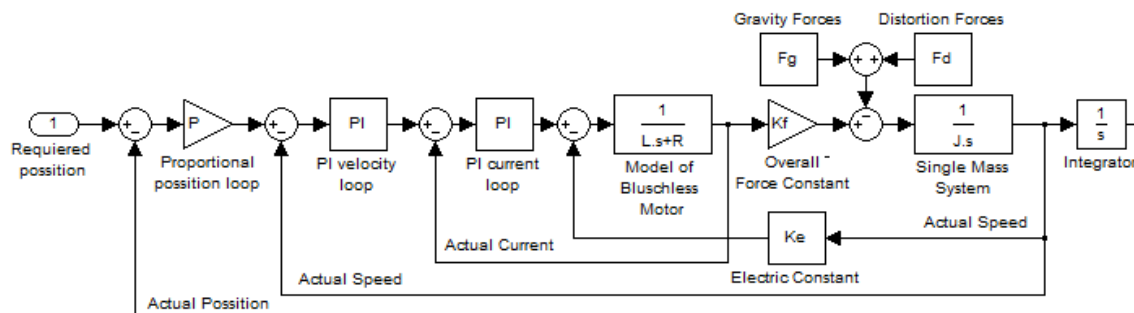
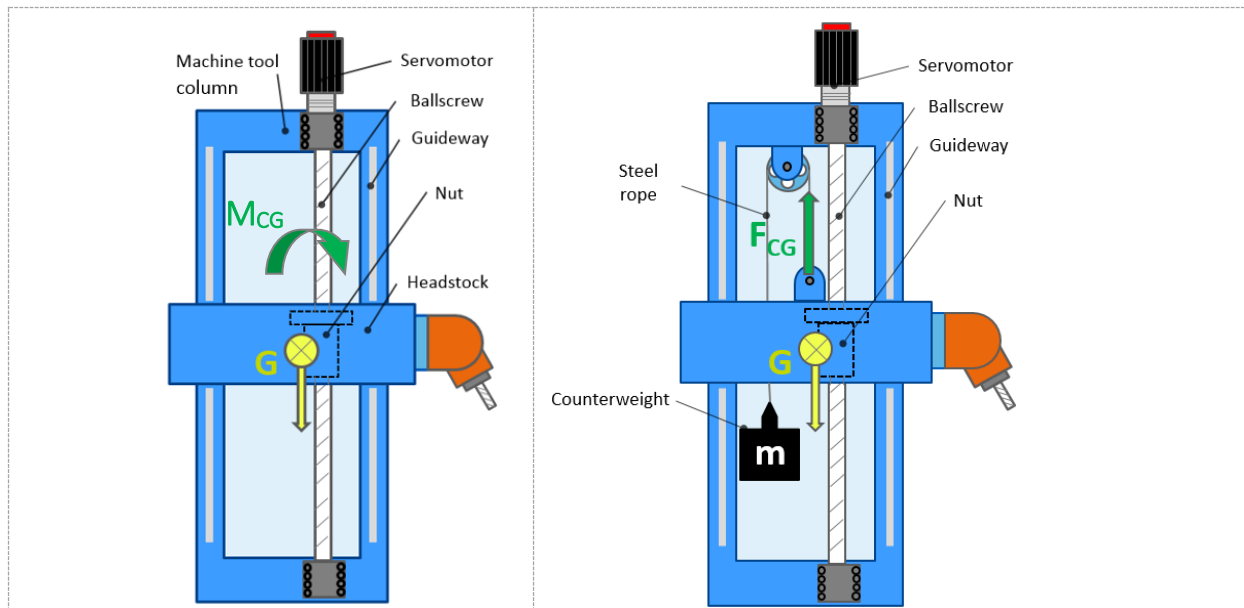

Fig. 1 Model of Cascade Regulatory Scheme With Brushless Motor and Single Mass System [2]

The machine reaches the required position and the position deviation falls to zero. The same goes for a velocity deviation and the current deviation falls to zero as well if friction forces are neglected. This ideal even state would be disturbed by either changing the required position, or by a disturbing force  $F_d$ . If a disturbing force occurs, a current compensator reacts so that  $J$  mass acceleration is avoided.

From the vertical axis perspective it is apparent that reaching the required position, velocity and position deviations fall to zero. The current deviation, however, is stabilized at a value corresponding to the amplitude of gravitational force of moving components. This implies that even if the axis is in the required position, the current flows through the motor while the motor is in a control loop in both cases.



*Fig. 2 Moving Axis Without Balancing And With Counterweight*

The effects of gravitational and counter-balancing (CB) forces are obvious in Fig. 2 for both examples with and without counter-balancing. The servomotor ( $M_{CG}$  torque) holds moving components without balancing. The counter-weight compensates gravitational effects; however the cable and chain force transfers do not allow changing direction if acceleration required is higher than  $1g$ . Greater acceleration causes relaxing to the rope which implies a significant change of axis load. Heavy machine tools generally accelerate in all directions with an acceleration greater than  $1.5g$ . This is why using counter-weight mechanisms is common only with exceedingly large machine tools, and this is receding in the new constructions. Another disadvantage is that a machine column weight is increased, more so if the column is movable.

Another option of balancing of vertical moving components is a hydraulic approach. The reaction force can be act by using hydraulic cylinders (Fig. 3) and thus the elimination of gravitational forces on the actuator can be achieved. For hydraulic cylinders, it is necessary to ensure a sufficient stroke. The simplest way is to use cylinders with stroke of piston rod same as axis length, but installation dimensions of machines will be doubled. Another possibility is the use of pulleys and chains. This is a very common solution for heavy machine tools. The inequality of the chain run has adverse effect on overall accuracy of the machine, and if hydraulic circuit is inappropriately sized it may cause a situation similar to the counterweight. Rare balancing method is the use of telescopic cylinders. Those are single-acting linear hydraulic motors and each segments are fed synchronously. Their acquisition is very expensive, production is in the order of pieces and all synchronous telescopic cylinders are

made to fit a given machine. Another disadvantage is that the force of the cylinder is determined by the smallest diameter of the piston segment. Thus the hydraulic cylinder really huge, the achievable power isn't corresponding.

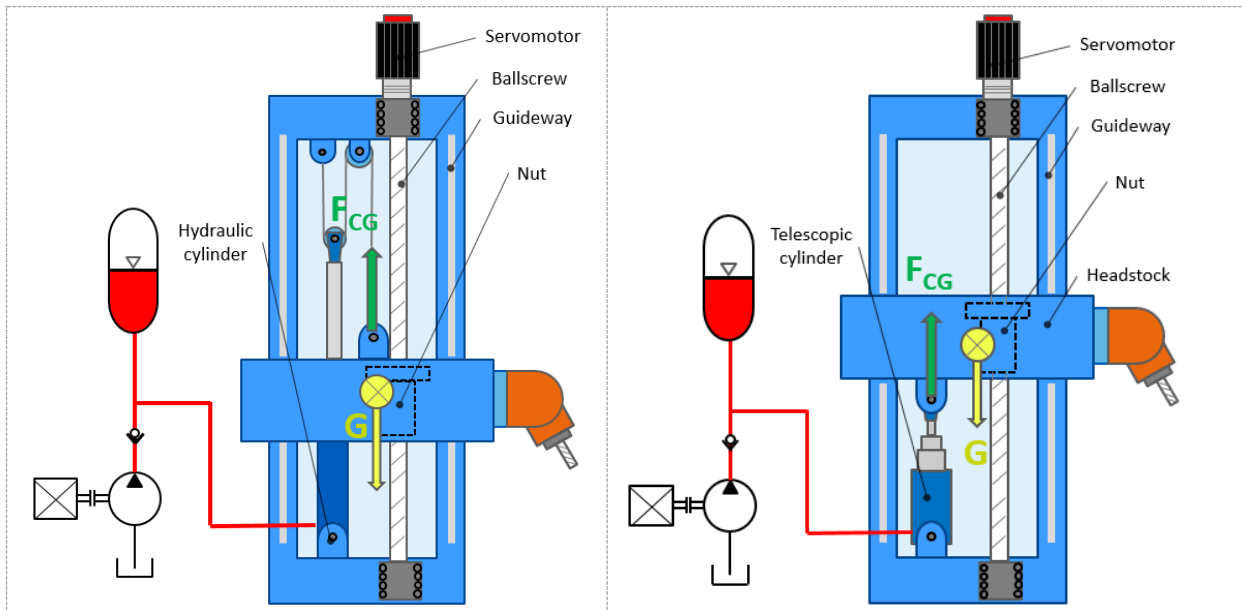

Fig. 3 Counterbalancing With Hydraulic Cylinders

From Newton's law of force implies that the force for accelerating the mass is directly proportional to its mass and the desired acceleration.

$$F_M = F_a = ma \quad (1)$$

Design of the servodrive unit of ideally balanced machines will match the headstock weight and the desired acceleration (1). Actuator sizing of unbalanced axis must also respect the gravitational force of the headstock. Upward accelerating force will be increased by the force required to maintain the components (2).

$$F_M = F_a + F_{CG} \quad (2)$$

Without a balancing, current is consumed to maintain the position of the component. Limitation of force for the counterweight balanced machine is given by achievable mechanical acceleration. At the same headstock weight is servodrive power of balanced machine use only for the desired acceleration. For machines without balancing must servodrive hold components by current.

## 2. Balancing System Using a Rotary Piston Hydromotor

By connecting the hydraulic motor to a source of a constant pressure acts torque on the output shaft. To compensate the gravity forces, it was necessary to convert the torque to the vertical direction force. For this purpose serve a rack and a pinion. This is a transformation pair, which allows the construction of endless motion axis. Thus in the machine design phase isn't important how long the vertical axis will be. Useful volume of the hydraulic accumulator must be adapted to axis length and to reduce the difference of torque at the top and at the bottom of the axis pressure bottle should be well dimensioned. Another advantage of using the rack and pinion option of drive is the opportunity to build a counterbalance system to the already exist machine. It is also possible for better compensating forces distribution the usage of multiple balancing units on a single rack or the usage of multiple racks.

## 2.1 Experimental Rig

The machine frame was fitted with linear guide ways and toothed rack. Moving mass was represented by headstock and servo drive and balancing assemblies.

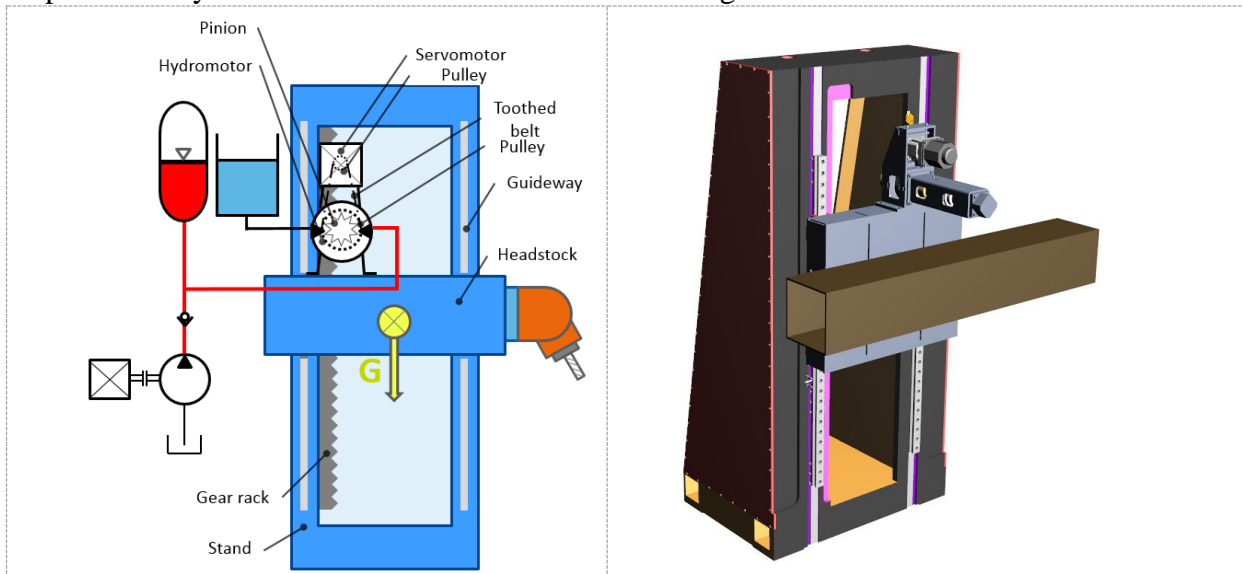

*Fig. 4 Counterballancing system with rotary hydromotor*

The scheme in Fig. 5 shows the composition of the drive and balancing assembly of one driving pinion. Hydromotor coaxially connected to a torque transducer and the pinion ensures the balancing function. Servomotor with planetary gearbox was attached to the previous line with tooth belt in parallel. It is responsible for the precise positioning and dynamic movements.

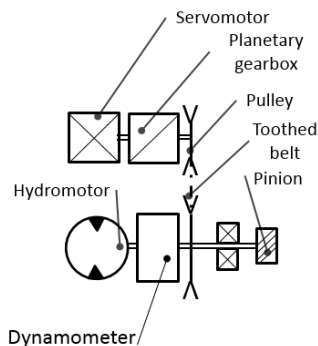

*Fig. 5 Scheme of Drive Assembly*

As already mentioned, in a well-balanced axis the drive can be dimensioned purely on the dynamic forces, but with respect of safety, it is appropriate that the drive can hold the weight of the moving components itself. The failure of the hydraulic system could cause overloading of undersized frequency converter or servodrive and thus equipment could breakdown. Possible security option could be adequately dimensioned motor brake. When a power supply and hydraulics would be lost the motor break should be activated and the headstock would hold the position.

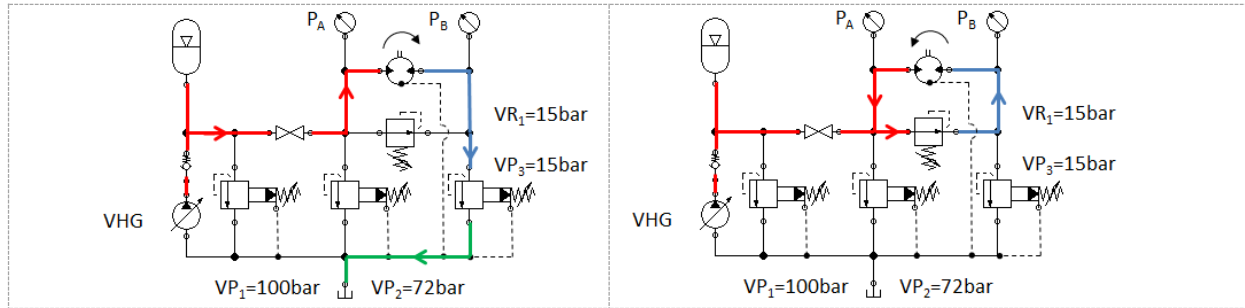

*Fig. 6 Hydraulic Circuit Scheme [3]*

Laboratory conditions allowed choice of hydraulic aggregate with pressure control and accumulator with a capacity of 25L. Due to the necessity of filling waste branches during movement against the direction of pressure gradient, it was necessary to provide overpressure to the return line.

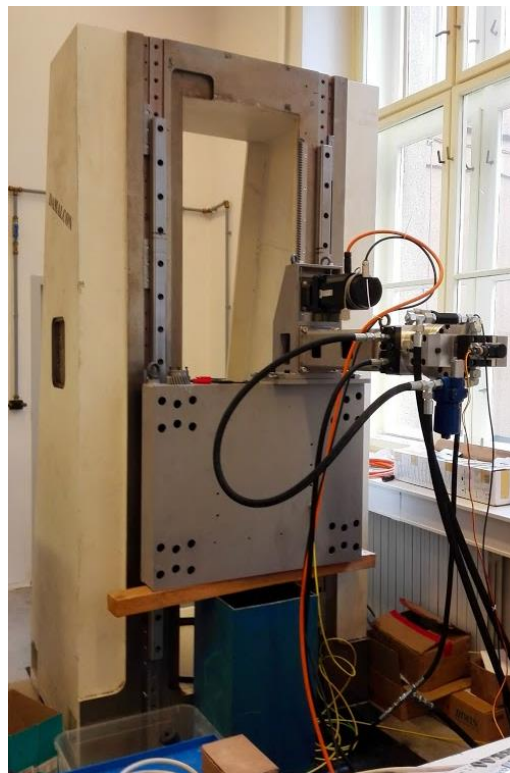

*Fig. 7 Experimental Rig*

## 2.2 Experiment

The hydraulic circuit connected as shown in Fig. 6 do not allow energy recuperation in hydraulics. For energy saving solution would be necessary to add a hydraulic oil reservoir to the output line. Waste line would be filled with the oil when the rotation will be reverse (counterclockwise pressure drop). Such a reservoir in the first phase of the experiment was not available. The energy-efficient solution will be subject of the future experiments. Servodrive sizing corresponded to the total weight of the motion components. Thus it was possible to carry out comparative measurements between unbalanced and balanced machine. Since it was used an axial piston hydraulic motor, it was necessary to determine whether the pulsations of the hydraulic motor will not adversely affect the smoothness of the movement.

Balancing functionality was tested in uniform motion at a defined speed. Defined trajectory was possible to insure either switched balancing or either off. From Fig. 8 shows that the desired position is a ramp position at a rate 50 mm / sec to 600 mm and back to zero.

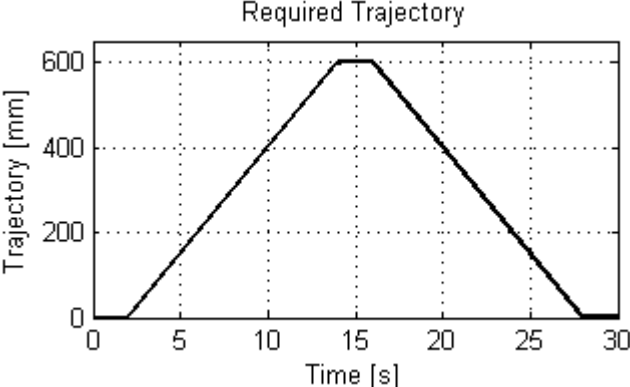

Fig. 8 Required Position Trajectory

The current flowing through the actuator is shown in Fig. 9. Here can be seen current increase during upward motion and current decrease during downwards motion. The chart is a comparison of the current on the machines servodrive without balancing and with balancing. There is also noticeable that when the axis is moving downwards, current jumps into negative values. This indicates that the pressure at the hydraulic motor is too large, and the servodrive pushes against the hydraulic motor.

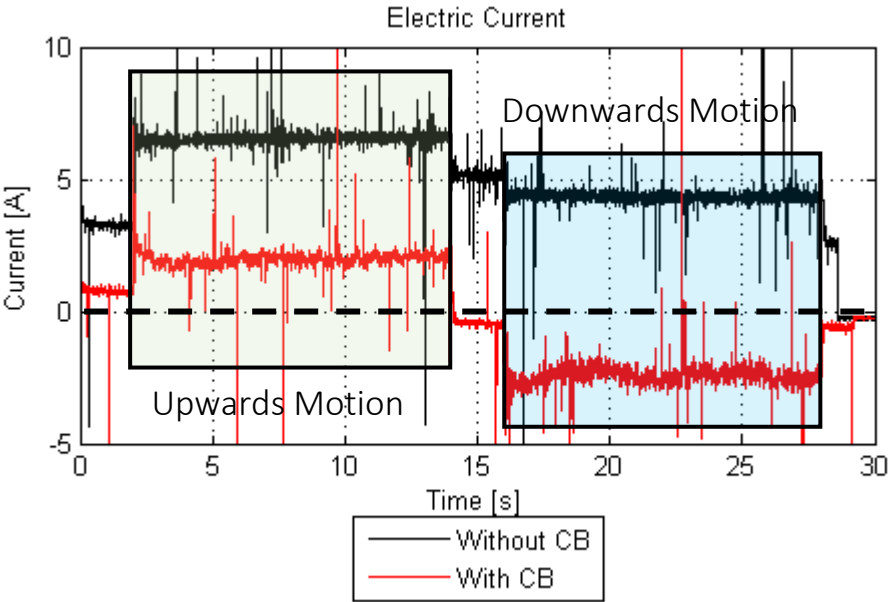

Fig. 9 Servomotor Current Characterisitcs

When moving without balancing the current appears to be almost constant up to noise. When the hydraulics is turned on, the current on servomotor is influenced by torque from the hydromotor. It is noticeable how regulation with respect to the requirement of smooth movement, must respond to load changes. This is the reason why is current on the servomotor wavy. Energy savings of hydraulic balancing mechanism is evident in both directions of movement. Current drop is approximately 70%. In Fig. 10 it is possible to see the characteristics of the torque on the dynamometer directly behind the hydraulic motor. It is

possible to perceive a similar tendency as in the case of current. Therefore it can be said that the current to the servodrive is rippled due to torque cogging on the hydromotor.

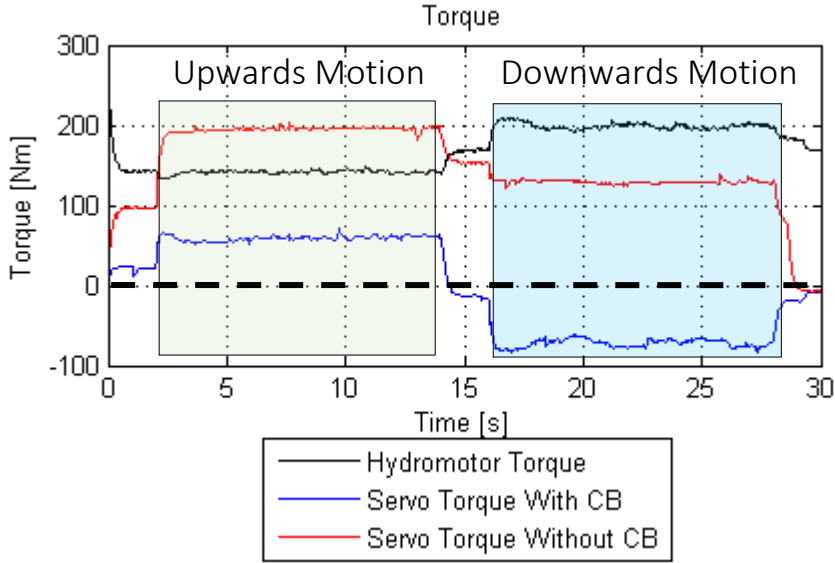

Fig. 10 Hydromotor Meassured Torque

Difference desired position and actual position is evident in the graphs Fig. 11. Oscillation around the constant deviation in the case of unbalanced machine is  $\pm 0.015$  mm in the case of machines with activated counterbalance  $\pm 0.05$  mm. This is an issue that needs to be solved in the following tests and it's necessary to try eliminate the influence of the hydraulic motor on accuracy, especially during very slow movements (e.g. circular interpolation).

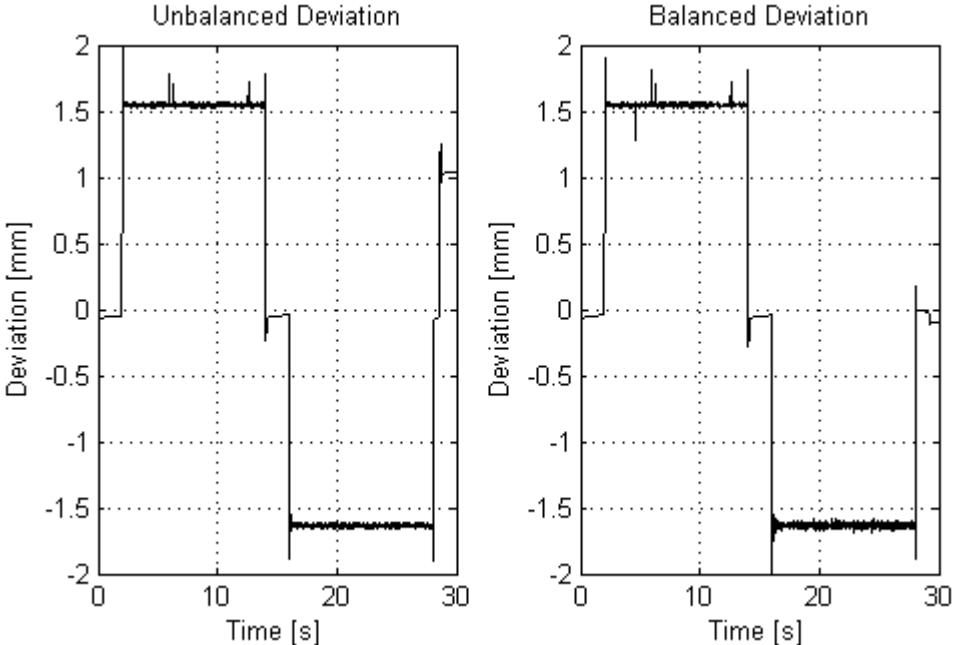

Fig. 11 Possition Deviation of Balanced and Unbalanced Motion

**2.3 Planned tests**

The experimental rig's servodrive is being rebuilt to servodrive with a safety brake. Identical measurements, as referred in this article will be carried out again and then hydraulic circuit

will be rebuilt to gravity filling waste branch. This removes all elements for controlling the pressure.

### 3. Conclusion

Basic measurements of movements were performed on machine with balanced axis with hydraulic mechanism which uses rotary hydraulic motor. Hydraulic circuit did not allow energy recovery, but it was not important for balancing functionality. 70% current reduction was achieved in both directions when operating with pressure controlled hydrogenerator. Deviation with balancing significantly exceeded deviation without balancing which is a matter that the attention should be paid on in the future. The balancing mechanism with a constant hydraulic motor can't respond to changes in pressure. The output torque is the product of pressure and geometric volume. Due to the possibility of change of the geometric volume hydromotor, it will be possible to implement the torque control method which uses a servo-hydraulic adjusting mechanism.

#### *List of symbols*

$a$	Acceleration	(ms <sup>-2</sup> )
$CB$	Counter-Balancing	(-)
$F_a$	Acceleration Force	(N)
$F_{CG}$	Counter-Balancing Force	(N)
$F_d$	Distortion Force	(N)
$F_M$	Servodrive Force	(N)
$J$	Moment of Inertia	(kgm <sup>2</sup> )
$K_e$	Electric Constant	(V/1000min <sup>-1</sup> )
$K_f$	Overall Force Constant	(Nm/A)
$L$	Induction	(H)
$m$	Mass	(kg)
$P$	Proportional Gain	(s-1)
$PI$	Proportional-Integral controller	(-)
$R$	Electric Resistance	(Ω)

#### *Reference*

1. HOVORKA, J. ČR, PUV 2011 - 24635. 2011.
2. SOUČEK, P. *Servomechanismy ve výrobních strojích*. Praha (ČR): Vydavatelství ČVUT, 2004.
3. ŠTĚPÁN, F. Measurement fo a Radial Piston Hydromotor at Low Rotational Speed. In: *The 22th International Conference on Hydraulics and Pneumatics*. Praha: VŠB - Technical University of Ostrava, 2013, s. <http://ichp2013.vsb.cz>.