

Verification of Feasibility of a New Velocity Probe with Heated Films

Ing. Jan Punčochář

Supervisor: prof. Ing. Jiří Nožička, CSc.

Abstract

Článek se zabývá ověřením možnosti vývoje nového bodového měřidla rychlosti proudící tekutiny. Měřidlo rychlosti bude založeno na využití více žhavených filmů. Filmy budou připevněny na mnohostěnu. S pomocí kalibrace, provedené v aerodynamickém tunelu, bude možné určit jak rychlost nabíhající tekutiny, tak její směr. Pokud se potvrdí všechny předpoklady, bude měřidlo vhodnou náhradou například za víceotvorové rychlostní sondy. Bude však disponovat již digitálním výstupem, zvětší se také rozsah měřitelných úhlů nabíhající tekutiny

Key Words

Anemometry, heated film, velocity probe, velocity measurement in fluids

1. Introduction

Determining the velocity of flowing fluids has been one of the basic tasks of experimental fluid mechanics for a long time. In spite of that, researchers still face problems in making measurements, caused chiefly by the imperfections and limitations of measuring devices. The widely used Prandtl probe can be given as an example. Despite its widespread use in measurements, it has some inconvenient properties, such as a very limited range of angles of oncoming air flow for which the probe is usable. Other drawbacks include the necessity of running hoses from the probe to pressure transducers, which may be a problem for both probe installation and measured signal quality in some cases. Similar difficulties can be identified in other measuring devices that use other principles for velocity determination. The objective of the present project therefore is to design and validate a point velocity probe that will eliminate at least some of the fundamental problems of current velocity measuring devices. The new velocity probe should be small enough to cause practically no disturbance to the fluid flow and to ensure the sufficient evidence value of local velocity measurements. Another requirement concerns the sampling speed – the probe should be able to measure instantaneous velocity even in turbulent flows. The final important requirement is the ability to measure not only the absolute magnitude of the velocity, but also its spatial direction. The range of the directional applicability of the probe should be relatively large: the expected range is a spherical sector of at least $\pm 45^\circ$. This requirement is based on the anticipated practical use, where turning the probe so it points exactly opposite to the flow direction is not always readily feasible.

2. Measurement principle

The primary velocity measurement principle chosen for the new probe was velocity determination using heated elements. This method has both many advantages and many drawbacks. Some of the key advantages include a very fast response to velocity changes. This means that this type of velocity probe is frequently used for measuring fluctuations in turbulent flows, as it is one of the few types capable of registering such fluctuations. Another benefit of probes with heated elements is the small size of the measuring section. This ensures velocity is measured only in an almost point-shaped area, and the velocity reading measured is thus not a mean for a large area of flowing fluid (unlike vane anemometers, for instance). Miniaturisation in electronics offers another potential advantage of probes with heated elements. The control microelectronics can be installed very close to the measuring section, or even alternatively in the probe. The microelectronic inputs and outputs can be purely digital. These digital signals are then much more resistant to disturbance, making transfer of readings much more secure even for longer distances. A measuring device equipped with control microelectronics in this way is also much easier to prepare for installation in the measuring application, in contrast to devices requiring more equipment in the form of various transducers, control units, etc. Another great potential of this principle is the possible reduction in the price per measuring device. However, utilisation of this potential requires finding a sufficiently robust and versatile design for the whole probe, one which can be used in the overwhelming majority of applications without any major modifications. Another great advantage of probes based on heated elements is their wide measurement range. Measurements are conclusive starting from virtually zero velocity (0.05 m/s is typically quoted), up to several times the speed of sound. The measurement range depends primarily on probe calibration.

The current main problem with using heated elements in measurements is that they are prone to mechanical damage. Conventional probe design, whether with films or wires, is very delicate. This places a great demand on the purity of the fluid flowing past the element. The measurement device is very easily damaged due to the use of wires at diameters of single micrometres or films tenths of micrometres thick. Heated wires are admittedly easier to damage, but they can be replaced. If heated film is damaged, however, the entire probe is frequently destroyed. This sensitivity virtually precludes their deployment in measurements performed outside controlled laboratory sites, notably inspection measurements in real-world applications. It also precludes the use of heated probes with PIV measurements, for example, or other experimental methods using particles in the fluid. Another disadvantage is their sensitivity to other physical quantities besides merely velocity and temperature. Measurement readings can be influenced by things such as the concentration of substances in the fluid, pressure, etc.

3. Heated element

The first task of the project is to produce a versatile heated element. The requirements are ease of manufacture, versatile applicability as needed, and low price. The most convenient option is the design of a heated film placed on a Kapton printed circuit board. The Kapton joint is pliable; the thickness is 50 micrometres. The heated film is produced on the top surface of the circuit board using the vacuum metal deposition method. Vacuum deposition can create metallic patterns from many different materials on the substrate. The deposition can be achieved in two ways. One is metal deposition directly through a stencil with the required pattern; the other is deposition of a continuous layer of metal followed by the etching away of redundant areas. This also gives rise to one limitation: that of accuracy and resolution of the deposited pattern due to

production capabilities when making the stencil. Standard accuracy and resolution may be 0.1 millimetres. The films will be made of a chrome-nickel alloy (nichrome: 80% Ni, 20% Cr).

The metal can be vacuum-deposited in various patterns. There are several key criteria in their production. Firstly, the depth of the meander produced has to be sufficient so that its electrical resistivity and changes are measurable without difficulty. Further, the pattern has to be easy to produce without difficulty, which implies larger proportions. At the same time, the entire sensor has to be as small as possible to keep the measurements point-sized. In addition, there is the issue of whether to use multiple separate films in a single sensor. The result will be the

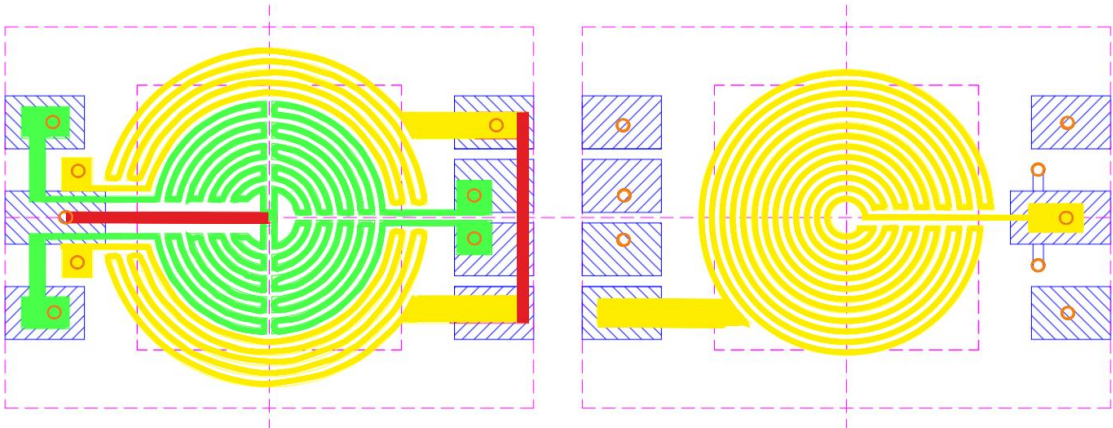

Fig. 1: Scheme of the larger sensor. Top side of the sensor is on the left, bottom side is on the right side of the figure. Green = heated film, yellow = guard heating, red = top Cu, blue = bottom Cu, orange = vias, violet = contours and construction lines.

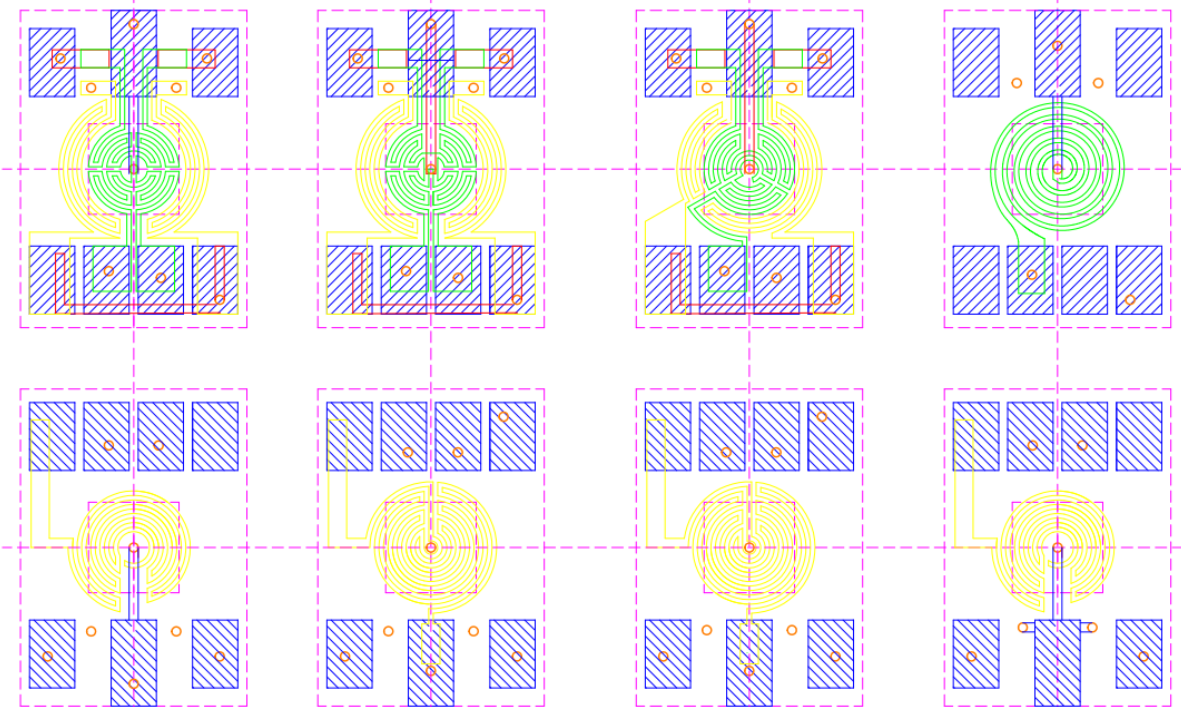

Fig. 2: Schemes of the four possible options of the smaller sensor. Upper row include top sides of the sensors, lower row bottom sides. Green = heated film, yellow = guard heating, red = top Cu, blue = bottom Cu, orange = vias, violet = contours and constructi

identification of the 2D velocity direction past the element using a single sensor. This yields more velocity information at the same price per sensor. The control and interpretation microelectronics will be more complex, though. The objective of the testing will be to find out whether this modification pays off.

After all the criteria are applied, the resulting meander has characteristic dimensions (conductor width and gap width) at the lower resolution limit, i.e. 0.1 mm. The diameter of the smallest 2D measuring element (with four separate films) with an acceptable resistivity of 11 ohms will thus be 3 mm. The size of the entire sensor will then be 5 x 7 mm. A sensor with a single measuring film will have a resistivity of approximately 40 ohms. A sensor with a larger measurement area (diameter 5 mm, sensor dimensions 7.2 x 10 mm) will also be tested.

Before the heated film pattern deposition, the printed circuit board is fitted with areas for connecting the film with copper conductors onto the upper surface, and with soldering pads on the bottom side. The soldering pads can be used to connect the finished sensor with a substrate conductively. The substrate shall contain conductors connecting the heated film with the control electronics. This design enables us to consider the heated element as an ordinary SMD component – it constitutes the sensor in this way. This guarantees sufficient versatility. A large quantity of identical SMD sensors can be manufactured and then applied to variously shaped substrates as needed. This concept will make the probes cheaper, because the sensor constitutes the majority of the cost per probe.

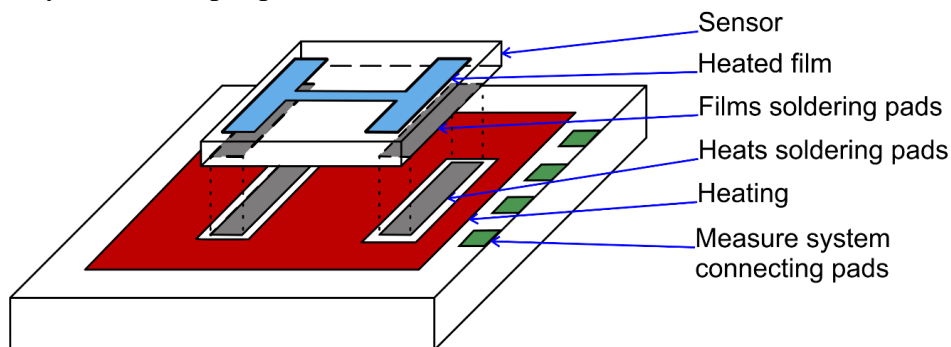

Fig. 3: Scheme of the assembling sensor

One of the major problems with heated films applied to a substrate is that the heat is transferred not only to the flowing fluid but also to the substrate. This distorts the measurement, because it is usually difficult to determine the accurate relative portion of the heat transferred to the substrate and the fluid, thus preventing correct interpretation of the fluid velocity. One possible solution is to use a guard heating. The presented method will work well in particular if the film is heated to a constant temperature. Then, another heated film can be placed on the bottom side of the sensor – a so-called guard heating – that will be heated to the same temperature as the measuring film. The purpose of the guard heating will only be to compensate the temperature gradient between the measuring film and the substrate. All the heat from the measuring section of the sensor is shared with the flowing fluid only. To prevent sideways heat transfer from the measuring film, the sensor will be equipped with an auxiliary protective heater along the perimeter of the measuring film. The function of these protective elements will need to be tested, which is why they are equipped with separate power supply for ease of control. The disadvantage of the protective heater – the sideways one in particular – will be the warming of the fluid stream immediately around the sensor. As such, its contribution will also be carefully examined. Another question is the overall necessity of such protection, since the Kapton film

itself has very low thermal conductivity and as such not much heat should be transferred from the measuring film to the substrate.

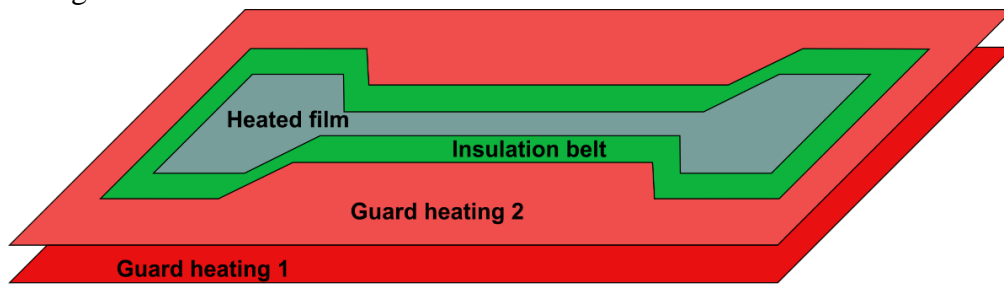

Fig. 4: Scheme of the sensor with guard heatings

4. Probe design

The measuring section of the probe will be a polyhedron. The heated measuring elements will be mounted on its faces. The different heated elements will be cooled differently by the oncoming fluid stream as a result of being positioned in various directions. A direction interpretation will be made based on calibration data. The required number of differently oriented heated films for unambiguous determination of the flow direction will be subject to experiment, testing various probe shapes with different numbers of faces. One of the faces will be a technology face for cabling and attachment to the substrate. Finding the most convenient shape of the polyhedron is one of the project goals.

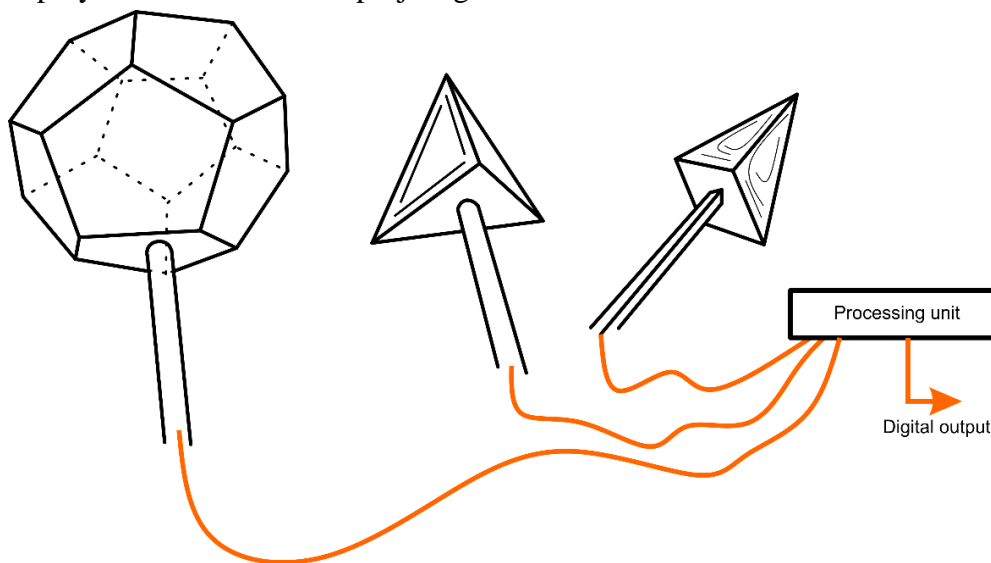

Fig. 5: Possible shapes of the probes

Another motivation for testing various shapes of the measuring section of the probe is the endeavour to find a shape that would guarantee an identical type of flow for the entire range of velocities measured, if this is possible. The aim is to minimise the consequences of flow transition from the laminar area to turbulence. To prevent having to determine the nature of flow around the probe, it is desirable to find a probe shape that of itself constitutes the most efficient turbulator possible. In the case of the ideal probe body shape, the flow past the measuring elements will be the same type for all velocities. The quality of the turbulators will be demonstrated when analysing the calibration output, with an assumed jump in the measured output at the transition from laminar to turbulent flow around the probe. This will be caused by more intense heat transfer during turbulent flow.

The microelectronics required for controlling the probe will be mounted at the end of the shank with the heated films. This will make it possible to manufacture the actual probe small enough for the measurements to be truly point-sized. A thin shank will make it possible to put the required conductors outside the measurement area with minimal impact on the fluid flow. Another advantage will be the lower requirement on miniaturisation of the control electronics, and thus its easier design.

5. Calibration

A module inserted in a wind tunnel will be produced for calibration of the new probe. The surface of the module measurement area will be identical to the cross section of the wind tunnels operated at the laboratories of Institute 12112 of the Faculty of Mechanical Engineering, Czech Technical University in Prague. The module will be equipped with all the devices for the calibration so that it is easily carried from one tunnel to another. The calibration will be made so that the measured probe is always in the same point of the tunnel, only rotating along three mutually perpendicular axes.

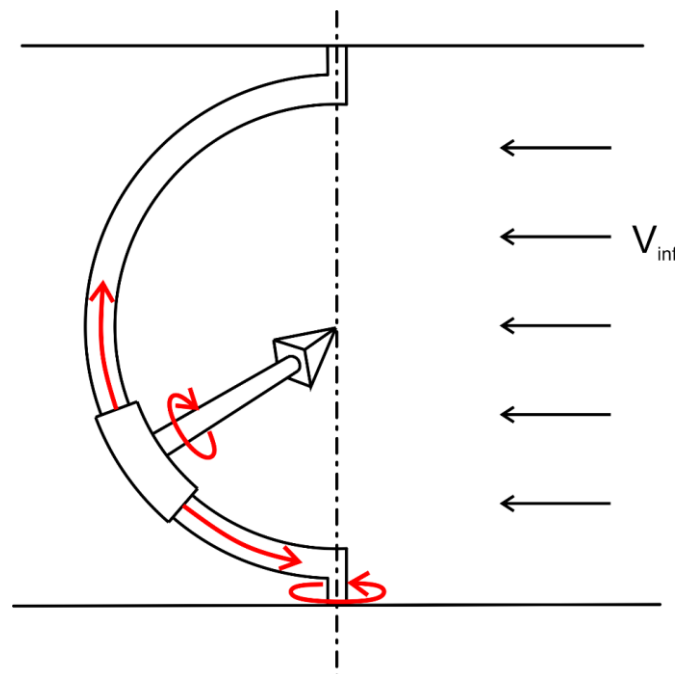

Fig. 6: Idea of the calibration device

The module will be equipped with a semicircular rail of an H-shaped cross section with an inserted geared belt to ensure the probe movement is purely rotational. The rail will rotate along the vertical axis intersecting with the centre of the semicircle. A trolley with three cogwheels, ensuring trolley travel without slippage alongside hold-down springs, will travel along the rail. A stepping motor attached to one of the wheels will ensure trolley movement. Position will be defined by the number of revolutions of the stepping motor and a precision rotary position sensor. Another stepping motor attached to the trolley will control the last axis of probe rotation. This will ensure probe rotation along the longitudinal axis of the shank.

Control electronics with their own microcomputer will be produced for movement control. The microcomputer will ensure operation of the stepping motors and work with the feedback provided by rotary and end switches. Another function of the microcomputer will be to

communicate with a superior logical unit – a desktop computer. The computer will enable the invoking of various functions for movement controls programmed into the control board.

6. Summary

Project SGS15/064/OHK2/1T/12 will involve the development of a new type of point-sized measurement probe. This probe will feature several essential properties that will enable its broad versatile deployment in measurement. The probe will measure the size and direction of velocity. Direction will be determined reliably within a wide range of angles wider than the norm today for multi-opening velocity probes. The application of the principle of heated films for measurement will enable the probe to take measurements starting from near-zero velocities. Calibration will then validate the functionality of the entire velocity probe concept. The result will thus be a design with the most convenient shape of the velocity probe and manufacturing process. In addition, a module will be built for wind tunnels, allowing calibration of the probe at various rotation angles.

Once viability has been proven, the concept can be developed further. Theoretical aspects in particular will be boosted. A calibration methodology will be elaborated afterwards, applying heat transfer theory to this specific task. The goal will be the ability to carry out calibration for only a small number of selected calibration points and then make a calculation for the entire calibration area. Under current conditions, the probe will have to be calibrated separately for each angle, temperature and velocity. Further developments will chiefly focus on the mechanical design of the probe. The probe will be enveloped in a covering film to increase its resilience. This will lead firstly to applicability of the probe even in environments with increased dust particle concentrations, and secondly to usability of the same probe for measuring velocities in fluids. Additionally, covering the probe to protect it against water will enable calibration in a water course, which is less demanding.

Seznam použité literatury

- [1] LENATHAN, K. *Hot-Film and Hot-Wire Anemometry for a Boundary Layer Active Control Test*. NASA Aeronautics Scholarship. Summer 2013, Final Report.
- [2] ETRATI, A., E. Assadian, R. B. Bhiladvala. *Analyzing guard-heating to enable accurate hot-film wall shear stress measurements for turbulent flows*. International Journal of Heat and Mass Transfer. 18 December 2013.
- [3] QUE, Ruiyi a Rong ZHU. *A Two-Dimensional Flow Sensor with Integrated Micro Thermal Sensing Elements and a Back Propagation Neural Network*. Sensors [online]. 2013, č. 14 [cit. 2014-10-05]. DOI: 10.3390/s140100564. <http://www.mdpi.com/1424-8220/14/1/564/htm>
- [4] MANGALAM, A. S., T. R. Moes. *Real-time Unsteady Loads Measurement Using Hot-Film Sensors*. NASA/TM-2004-212854. NASA STI Program 2004.
- [5] INCROPERA, Frank P. *Introduction to heat transfer*. 5th ed. /. Hobokenm NJ: Wiley, c2007, xxv, 901 p. ISBN 0471457272-.