

A Construction of polishing machine cooperating with the robot

Ing. Stanislav Hosnedl

Vedoucí práce: doc. Ing. Vladimír Andrlík, CSc.

Abstrakt:

Předložená práce se zabývá konstrukčním návrhem leštícího stroje spolupracujícího s robotem a jeho využitím v praxi. Trendem posledních let je nahrazovat lidskou práci robotickou prací, samozřejmě tam, kde to jde, nebo kde je nebezpečné prostředí, či prašné prostředí, jako například při leštění. Cílem práce bylo provést řešení trhu, zabývajícího se výrobou leštících strojů spolupracujících s robotem. A dále vylepšit tento stroj, dle požadavků firmy ABB s.r.o..

Key words:

Polishing machine, automated polishing, high pressure guns.

1. Introduction

A polishing is a final operation in which we get a perfect mirror appearance without accuracy requirements. The polishing machine is hardly pushing on the polishing surface, the polishing machine means a polishing wheel or polishing pad made from soft material (for example felt, foam, sisal, wool, textile, etc.). During polishing must be used a polishing emulsions in a liquid or solid form. When the polishing wheel is rubbing the polishing surface, the impurities and rest of the polishing emulsions are released into the air. This polluted air is not health perspective for a long-term human presence, that's why human working should be replaced with a robotized workplace. The robotized workplace is also profitable to speed-up a production time as regards a serial production.

2. Construction

2.1. Requirement of construction

Requirements of design come out from a market research of polishing machine's production. One of the most important requirement is a force measurement of pushing a polishing wheel on the polishing surface. Other requirements include a regulation of a spindle speed, guns for spraying a polishing emulsions, dispenser for solid pastes bar feeder or measuring of a wheel's diameter. At the request of the company ABB s.r.o., has been designed an automatical cleaner of sedimented bar feeder on the polishing wheel, which makes little burls on the surface of the polishing wheel. Meantime, this wheel cleaning is realized on machines by human hand only. Getting of automatical cleaning will lead to reduce a human impact during machine's working.

2.2. Construction of polishing machine

The designed polishing machine is shown at Fig. 1 consisting from two main components of a base (1) and a machine table (2), which is attached on linear guideways. This unific solution of a moving table of a polishing machine helps regulate a decrease of wearing off the polishing wheel during polishing procedures. This robotic polishing machine can regulated

the size of a contact force and can prevent a collision with a polishing surface. The engine (3) situated into a base of polishing machine cause of a decreasing weight of machine table, transfers a torque moment per belt driver (6) to the shaft (5). There are attached a polishing wheel (4) on both sides of the shaft. Two polishing wheels are used because of usual polishing in two operations, during first operation is used greasier emulsion with coarser grains. During the second operation the emulsion is drier with finer grains for the greater shine.

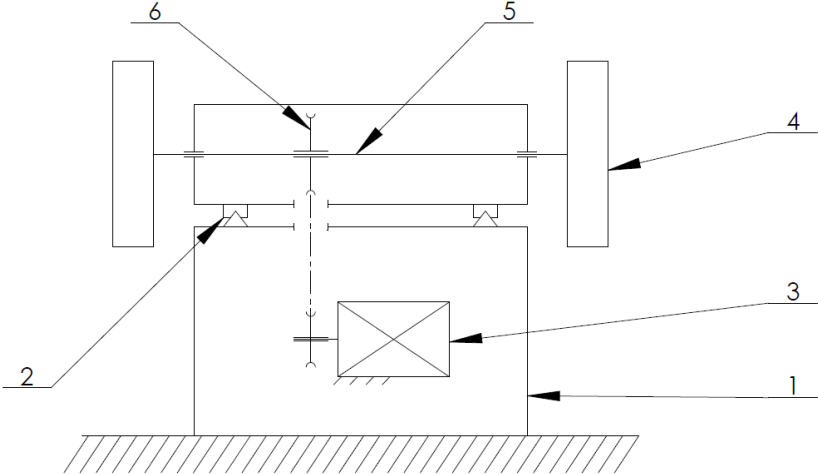

Fig. 1 Sketch of polishing machine

- 1. Base, 2. Machine table, 3. Engine, 4. Polishing wheel, 5. Shaft, 6. Belt driver.

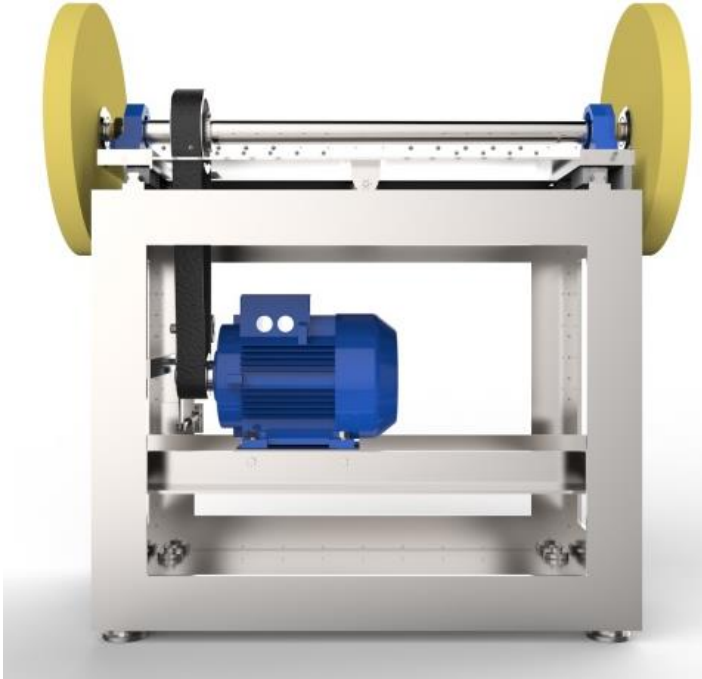

Fig. 2 No covers polishing machine

How it has been mentioned, design of polishing machine is unique because of the machine table with polishing wheel, which helps regulate a wearing off the wheel’s diameter. The regulation is ensured by the machine table moving on at the linear guideways perpendicular to the axis of the shaft. The table moving is realized by a pneumatic actuator with an encoder system for measuring an actual location. The moving range is only 80 mm long, but it is enough due to the size of the diameter of polishing wheels which reaches 500 mm.

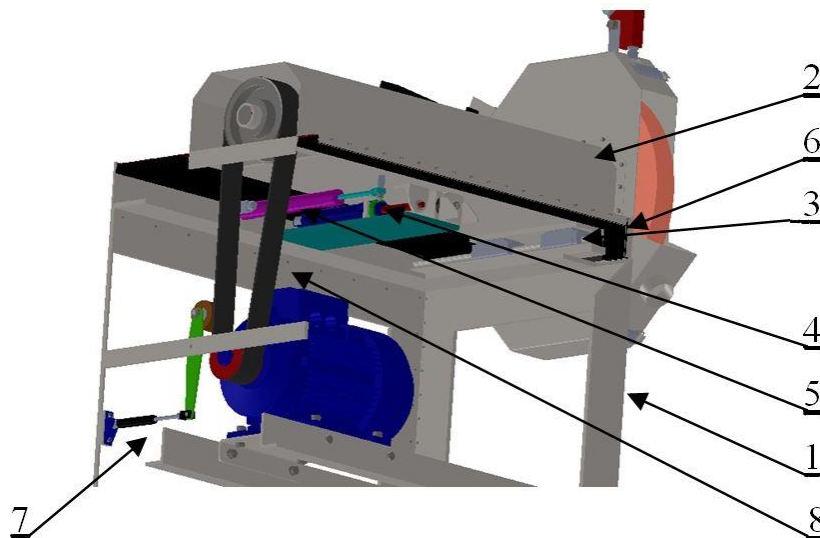

Fig. 3 Cut of polishing machine

1. Base, 2. Machine table, 3. Linear guideway, 4. Pneumatic actuator, 5. Encoder system, 6. Covering bellows, 7. Stretching mechanism, 8. Belt

At first, it was necessary to choose an adequate transfer between the engine, which is fixed to the table, and the shaft moving with the table. Due to moving a shaft's axis towards engine's axis have been change an axis distance up to 2 mm. Therefore was choose belt transfer with a stretching mechanism compound of a gas spring and a leverage mechanism for pushing the pressure cylinder to the belt in order to stop slipping the belt. There are different request for number of engine speed that depends on the concrete polishing surface. The polishing machine is constructed for perimeter speed polishing wheel to 35 m/s, which represents a material from a stainless steel. The peripheral speed 35 m/s of 500 mm wheel in diameter corresponds 1350 rpm and cca 2600 rpm of engine. Of course, the number of engine speed is increased with the decreasing diameter of the polishing wheel (because of wearing off). The engine can fluently regulate a number of rotation speed by using a frequency driver.

It was necessary to set the critical frequency for the designed shaft with using the base equation of dynamic for undamped system (1). After the modification this equation, we get an equation for a calculation our own frequention (2), of which we can get first frequention $\Omega_1 = 1\ 532$ rad/s which corresponds a speed of 14 632 rpm. From thus is calculated the maximum operating speed, which is ten times lower than first own frequention.

$$M \cdot \ddot{\varphi} + K \cdot \varphi = f(t) \quad (1)$$

$$\det K - \Omega^2 \cdot M = 0 \quad (2)$$

The Fig. 4 shows no cover workspace of polishing wheel. The first important element here is the high-pressure gun for applying the polishing emulsion to the circuit of the polishing wheel. The high-pressure gun sprays 0,5 – 4 g of emulsion on a rotating polishing wheel under the pressure of 6 bars, which is repeated in cycles. You can also see an attaching a hose of a vacuum cleaner.

During the polishing, an aplicated emulsion on a polishing wheel has blubbered and producted burls on the surface of wheel, that's why is important to remove burls and keep the wheel clean. On Fig. 4 and Fig. 5 is shown a clearing cylinder with the measuring of wheel's diameter, the cleaning cylinder is able to rotate freely around its axis. There are located small protrusions in size ca 5 mm on its surface.

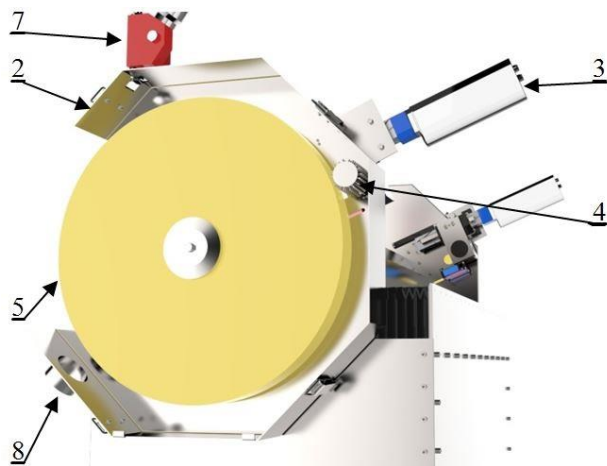

Fig. 4 No cover workspace of polishing machine

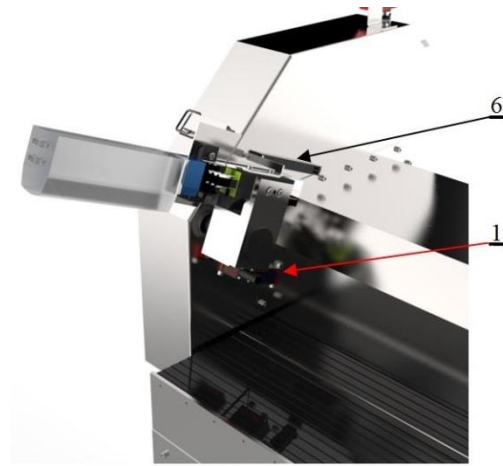

Fig. 5 Positioning unit

1. Laser measuring, 2. Cover, 3. positioning unit, 4. Clearing mechanism, 5. Polishing wheel, 6. Potentiometric ruler, 7. High-pressure gun, 8. Attaching a hose of a vacuum cleaner

Describing of cleaning mechanisms

The mechanism is put into the operation of a special mode of polishing machine (e.i. small peripheral speed of polishing wheel and at the same time with no load of wheels). At the beginning, the laser measuring (1) of wheel's diameter has been put on, thereby a laser beam is constantly transmitting in to the inner space of the shield of wheel (2). In doing so, a positioning unit (3) with the laser measuring and the cleaning cylinder are moving in the middle of polishing wheel (5). This impulse sends signal of position from potentiometric ruler (6) for the deduction and gives information of setting the correction of wheel's diameter.

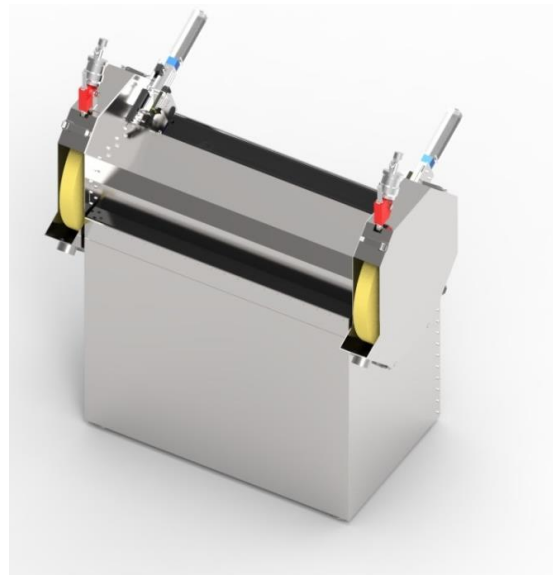

Fig. 6 Polishing machine

After the measuring a wheel's diameter, the laser measuring is put off and the cleaning cylinder is gotten into the polishing wheel only into a distance of protrusion's length. The cleaning cylinder is rolled on the polishing wheel, applied and dried rest of emulsion is scrubbed by protrusions.

During polishing is necessary to keep a constant polished force, which is developed by robot. A force measurement is realized by a force control located between the clamping flange of the robot and the gripping head.

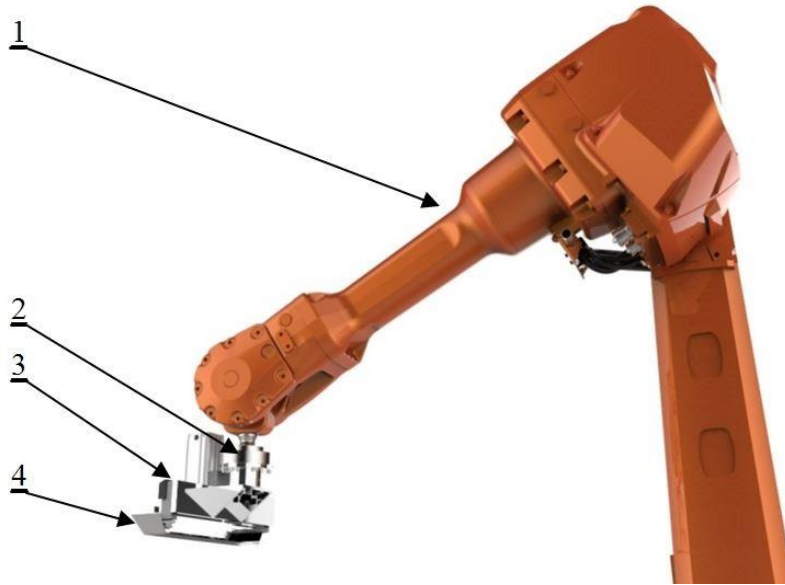

Fig. 7 Robot with force control
 1. Robot, 2. Force control, 3. Gripper head, 4. Polishing part



Fig. 8 Force control(2)

Force control is a sensor for control force and torque moment. It is used in machining applications implemented on the six-axis robot, such as milling, grinding, polishing, etc.

2.3. Parameters of polishing machine

Motor output:	5,5kW
Speed of polishing wheels:	min. 100 rpm (3 m/s) max. 1350 rpm (35 m/s)
Diameter of polishing wheels:	500 mm
Width of polishing wheel:	min. 25 mm max. 50 mm
Bore of polishing wheel:	45 mm
Distance between polishing wheels:	1000 mm
Table feed:	80 mm
Dimensions (L x W x H):	820x1220x1400 (mm)
Weight:	350 kg
Electrical connection:	400V/ 50Hz

3. Location of the polishing machine in the automated workplace

The automated polishing workplace is consisted of polishing machine operated by robot which with the gripper head pickes up a polishing part from the belt conveyor and then it is attached to the polishing wheel. Before this, it hasn't been know the position of the polished parts on a conveyor, this it has to take a camera for the deployment of parts. The picture created by the camera is sent to the evaluation software, which gives us the exact position of the orientation robot controller's parts.

All workplace is covered because of the safety reasons, and safety pressure mats are placed on the floor around a robot. The dust exactor is located behind a polishing machine out from the safety box, used for dust extraction during polishing.

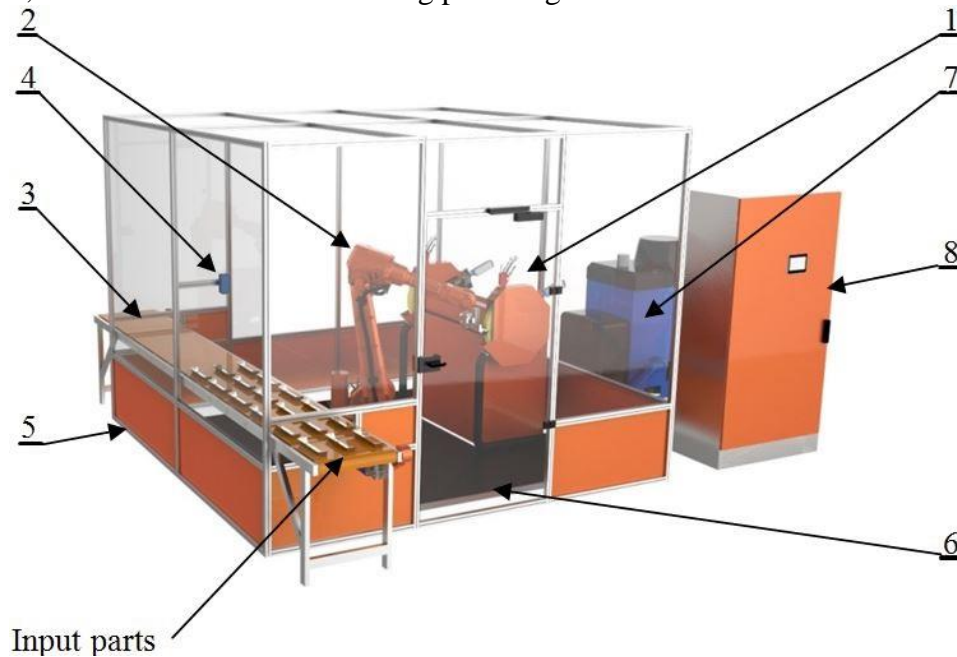

Fig. 9 The automated polishing workplace

1. Polishing machine, 2. Robot, 3. Belt conveyor, 4. Camera, 5. Safety box, 6. Safety pressure mats, 7. Dust extractor, 8. Distribution box

4. Conclusion

Designed construction is in an accordance with market requirements. There are automated application polishing emulsions using high pressure gun, stepless control of spindle rotary speed and measuring wearing off a polishing wheel. The construction is extended by automatic cleaning of wheel from rest of the emulsions and a movable table with a polishing wheel. Due to the movable table, the construction is unique from previously produced polishing machines, because it is able to compensate a wearing off the wheel's diameter on automated production. Therefore this compensation, a simple manipulator is able to operate the polishing machine in the case of very simple shaped polishing parts, currently in stead of an expensive robots.

List of symbols

$f(t)$		Force
K		Stiffness matrices
M		Mass matrices
φ		Nodal displacement
Ω	[rad/s]	Frequency

References

[1] HOSNEDL, Stanislav. *Konstrukce leštičky obsluhovaní robotem*. Praha, 2014. Diplomová práce. ČVUT v Praze. Vedoucí práce doc. Ing. Vladimír Andrlík, CSc.

[2] F/T Sensor: Mini58. *ATI Industrial Automation* [online]. 2015 [cit. 2015-04-06]. Dostupné z: http://www.ati-ia.com/products/ft/ft_models.aspx?id=Mini58